

# OPERATOR'S MANUAL

## AQUABLAST Elite

### Automatic Washout



# MBA

**MEDIA BLAST & ABRASIVES, INC.**

591 WEST APOLLO STREET  
BREA, CALIFORNIA 92821

714-257-0484

714-257-0184 FAX

[www.mediablast.com](http://www.mediablast.com) WEBSITE



NEVER ALLOW TO FREEZE

GFI CIRCUIT REQUIRED

# AquaBlast Elite Installation Information

1. Locate a 3/4 pipe x 3/4 garden hose fitting and install in the balance tank drain outlet valve located on the rear of the cabinet, #14 (machine control diagram page 5). Make sure to use Teflon tape to seal the threads. The ball valve is standard 3/4" NPT and hose threads are larger. Make sure to thread the finer threads into the shut-off valve. Always use two wrenches, one to hold the valve and one to tighten the fitting...use Teflon tape to seal.



2. Locate a 3/4 pipe x 3/4 pipe fitting and install in the water supply line inlet valve at the back of the cabinet, #12 (machine control diagram page 5). Always use two wrenches, one to hold the valve and one to tighten the fitting using Teflon tape to seal. **DO NOT ATTACH THE WATER SUPPLY HOSE AT THIS TIME THE WATER FLOW TEST IS FIRST!**



3. Make a 90-degree waste drain elbow if you are unable to find a PVC street elbow. Using a 90-degree PVC elbow and a short piece of PVC pipe, glue the nipple into one end of the elbow allowing 1-1/2" of nipple length for attachment to cabinet fitting. This has not been supplied to eliminate possible breakage during shipment and or customer drain configuration.



4. Glue a reducer bushing into the opposite end of the 90-degree elbow. Next glue another short piece of PVC pipe to allow attachment of the flexible drain connector.



5. It is now possible to glue and attach the waste drain elbow to the cabinet. Using the right end, glue the elbow making sure to slightly angle allowing the final drain location to miss the water supply ball valve.



6. Clamp one end of the rubber flexible adaptor to the down nipple of the waste drain outlet. It will be necessary to decide on the waste drain size being used. This is a low flow unit and the drain size is determined by the length of the drain and the number of elbows used in the installation. It is advised that the drain size be larger than smaller but the machine will operate with a 3/4" ID drain if the distance is minimal.



7. At this time you want to perform the water supply flow test found on page 6 and 7 of the manual **"Know the water supply flow volume"**. This is a simple test and must be performed before attachment of the water supply hose to the unit. The hose ID and length can be different sizes but the supply must flow 4 gallons or more per minute. If your test shows any volume above 3.9 gallons per minute the units will still only use 3.9 gpm during the washout cycle...the machine does not use a larger buffer tank for operation.

8. Last to be attached is the electrical power source. The unit has been shipped with 6' power cord and no plug end for hard wire hook-up. Most likely you already have an existing outlet and plug end permitting use of the existing cord plug without replacement of the outlet receiver. The machine requires a 220 volt, single phase, 60 cycle – 20 amperage service. Always consult a qualified electrician for machine hook-up and connection.



Tools



NEVER ALLOW TO FREEZE

GFI CIRCUIT REQUIRED

# SETTING UP THE AQUABLAST ELITE WASHOUT MACHINE

1 =

Remove machine from crate and locate using machine caster wheels

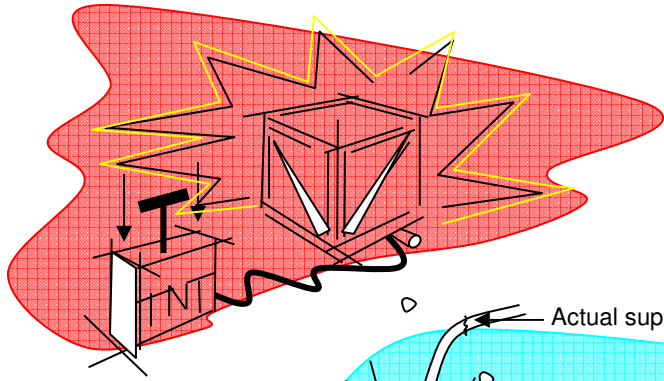

2 =

Check the water flow rate at the machine using actual supply hose at the installation location

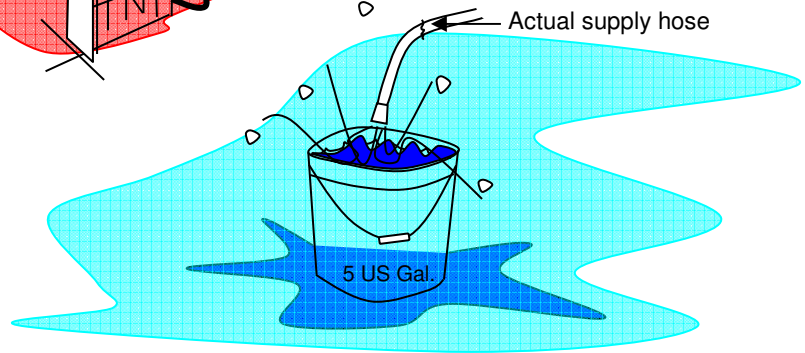

3 =

Connect washout drain and water supply using flexible drain section and hose

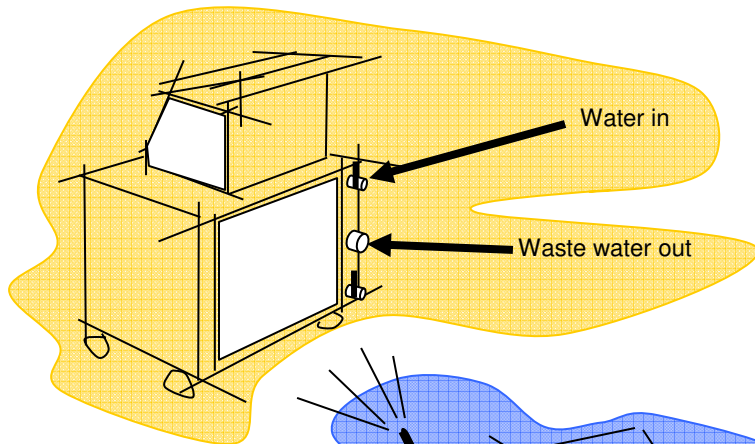

4 =

Fill water tank using manual washout gun for air escape, one time event this takes about 2 minutes

If the balance tank is ever drained for service you will need to repeat again to fill the tank with water

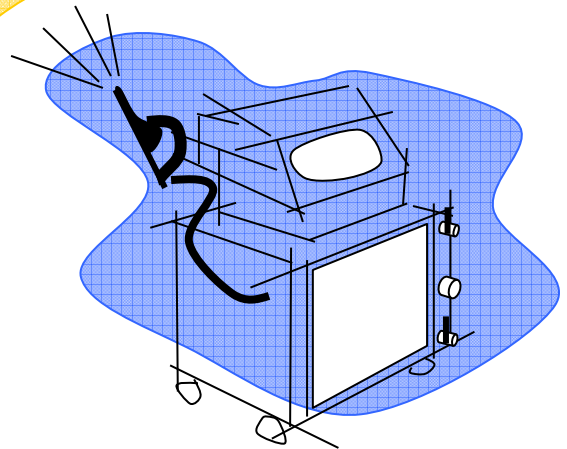

5 =

Make electrical connection to machine, 220 single phase 20 amp service

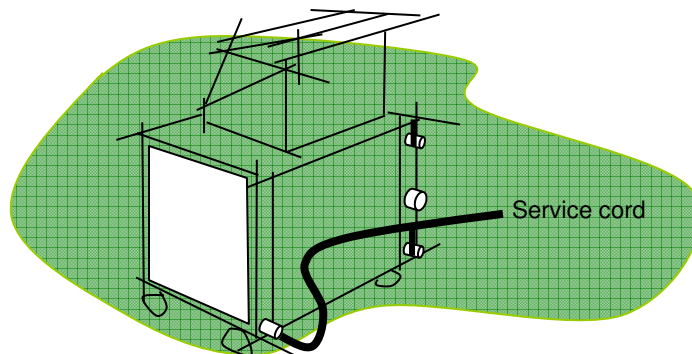

# TABLE OF CONTENTS

Installation parts & supplies needed



PVC primer & glue



Sized PVC 90 for drain



90 drain reducer bushing



Short PVC pipe piece for drain



Flexible drain coupling



3/4 pipe x 3/4 garden hose for balance tank drain



3/4 x 3/4 NPT water in fitting

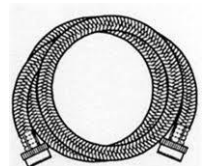

Water supply hose flow tested

<b>ELITE WASHOUT IMPORTANT ISSUES</b> -----	6-9
Machine Control Diagram -----	5
First Filling -----	6
Water Volume Required -----	6-7
Washout Chamber -----	7
Power Requirements -----	7
Water Requirements -----	7
Cycle Drain Requirements -----	7
Tank Drain Requirements -----	7-8
Water In Connection -----	8
First Filling -----	8
Review Entire Guide First -----	8-9
Customer Supplied Hot Water Requirements -----	9
<b>SET UP</b> -----	9-11
<b>OPERATION</b> -----	11-12
<b>DUTY CYCLE CHART</b> -----	12
<b>SERVICE AND MAINTENANCE</b> -----	13-16
Minimum Recommended Maintenance Schedule -----	13
Inspecting Fan Jet -----	13
Inspecting Y-Strainer -----	14
Replacing Washout Cover Seal -----	14
Adjusting Manifold Height -----	14
Setting Cycle Time -----	14
Reading Pressure and Temperature Gauge -----	14-15
Window Replacement -----	15
Flange Bearing Service -----	16
Pump Solenoid Service -----	16
Washout Gun Service -----	16
Jog Switch Service -----	16
Magnet Storage -----	16
Front and Rear Panel Removal -----	16
Drain Pan Removal -----	16
Draining the Balance Tank -----	16
<b>TROUBLE SHOOTING</b> -----	17
<b>PART LIST</b> -----	18
<b>WARRANTY</b> -----	19



Tools



Teflon tape

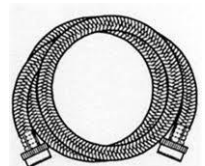

Water supply hose flow tested

# MACHINE CONTROL DIAGRAM

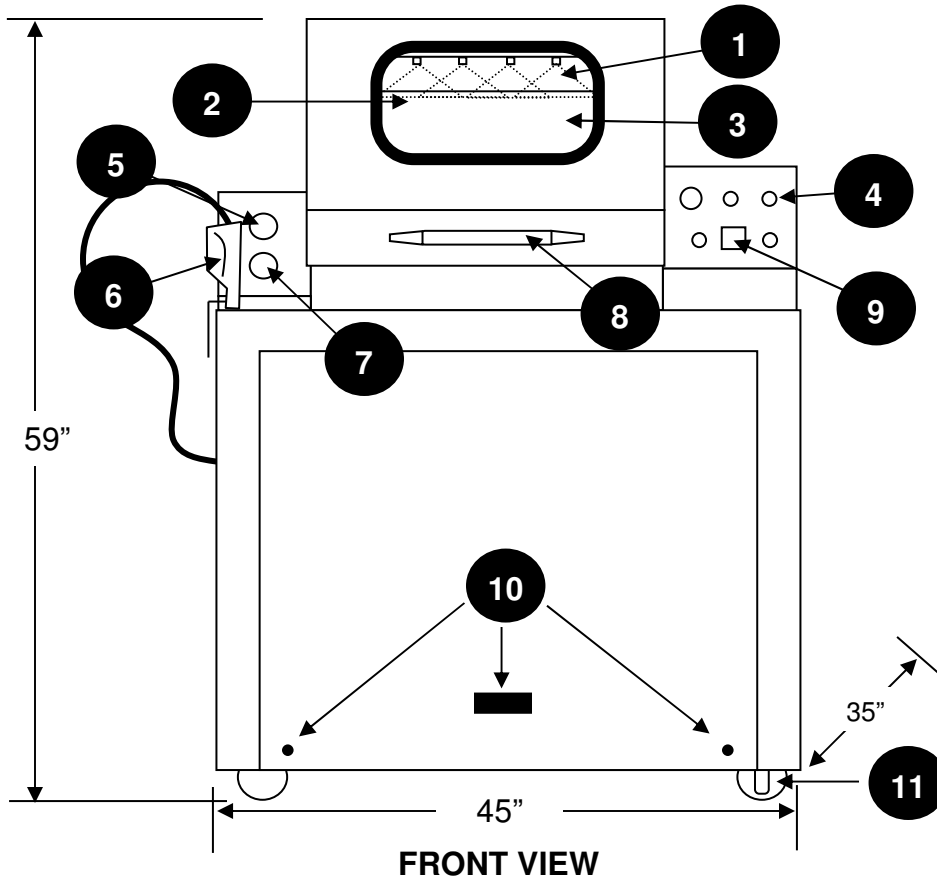

## KEY

1. Washout manifold, fan jets and LED lighting
2. Washout drum
3. Observation view window
4. Controls (top to bottom, left to right), Red Emergency Stop – Green Cycle – Jog with Pressure Rinse – 2<sup>nd</sup> row, Power On – Cycle Timer – LED Lights
5. Water temperature gauge
6. Manual washout gun
7. Water pressure gauge
8. Lifting handle
9. Cycle timer
10. Panel lifting hole and removal screws
11. Locking casters

## KEY

12. Water in
13. Waste water drain
14. Water balance tank drain
15. Panel lifting holes and removal screws
16. Electrical cord strain relief connector
17. Safety switch

220 volt – Single Phase,  
60 Hz – 20 Amp.  
Service

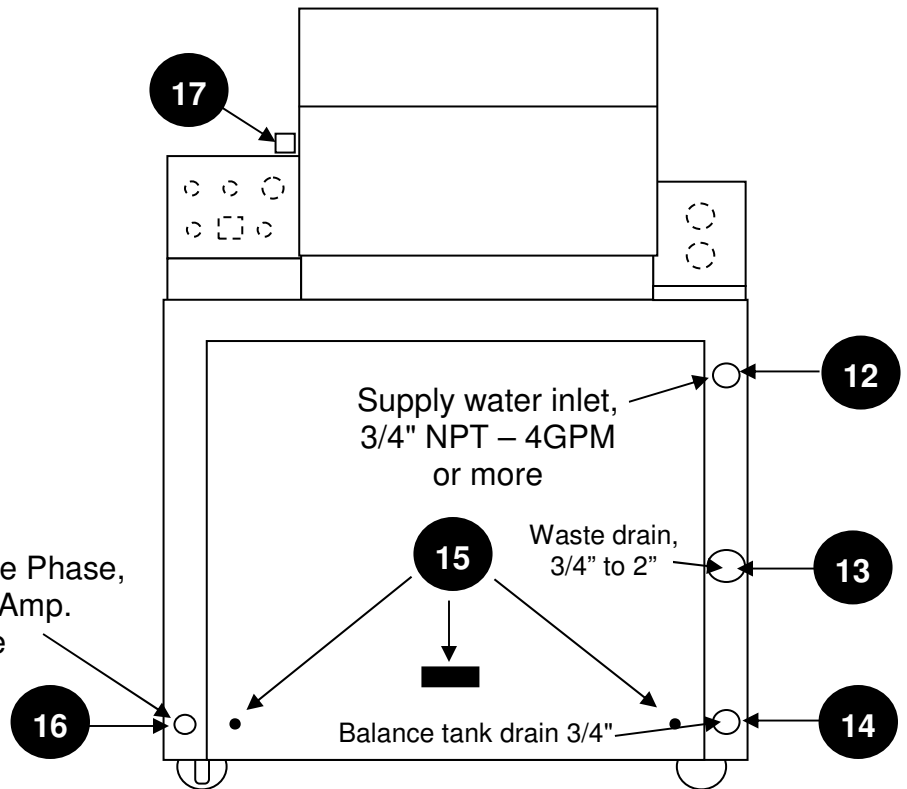

## REAR VIEW

# SET-UP MANUAL & OPERATION GUIDE

## AquaBlast Elite Automatic Washout Machine

### Important Issues

The AquaBlast Elite washout machine is a low maintenance pressurized unit designed for almost any required duty cycle from just a few cycles daily to 100s of cycles including continuous production. There are a few important issues which you should know and understand: The unit is a low water usage, high pressure design unlike existing automatic washout machines in the market today. Operation is not the same as other machines, the AquaBlast Elite does not use a large oversized buffer tank for water storage that can lose heat, humidity and still run out of water. The new AquaBlast Elite address the water recycle question by using 50-70 percent less water than other automatic washout units on the market today.

- ❖ **WATER REQUIREMENTS:** The new Elite offers the user the lowest cost of operation, fastest washout times with the highest efficiency of operation. The Elite does not use an open to atmosphere water storage buffer tank, this type of construction can result in possible tank overflows, loss of humidity and or valve failures resulting in a flooded mess not to mention the high hot water demand. The pressurized low flow design allows operation of the unit to stop at any time and continue hours later with no loss of tank holding temperature or water volume. This permits intermitent and constant film washout with minimum water usage keeping the washout time constant. Another plus with the pressurized system is the elimination of humidity loss often found with other older open to atmosphere water storage designs.

The AquaBlast Elite operates with a customer supplied total water loss system. This is a requirement to eliminate contamination maintenance and maintain consistant washout cycle times. Only limited usage manually operated units for very low production can operate with any % of recycled water.

The exact water supply required for the Elite, measured in gallons flow per minute, requires no open buffer tank with large water storage. See and refer to Duty Cycle Chart located on page eight for total cycles per hour vs. washout time. Water flowing into the unit during machine cycle is regulated by water flowing out the manifold during washout. The standard AquaBlast Elite manifold requires less than 4 gallons of water per minute, the extream ultra-low-flow manifold uses less than 3 gallons per minute.... the unit can never flow more than cycle demand, supplying large volumes of water is not required and this eliminates the large water storage buffer tank...more will be listed about water usage later.

It is advised the water heater supply source, customer supplied hot water tank or generator, be set at a lower temperature to maximize total capacity by reducing recovery time if cold and hot water is not blended at the machine water inlet. Call and discuss the blended water supply option, hot and cold water blending valve, or the On-Demand hot water supply that works with the new AquaBlast Elite low-flow design. The AquaBlast Elite does not lose water temperature when standing idle like other units in the marketplace and requires very little wattage to maintain temperature. The fully insulated pressurized sealed water tank has a special low watt water temperature maintenance circuit, about the same size as heating a single cup of tea, that will keep the holding tank at the correct temperature when standing idle for long time periods. You may view the water temperature and pressure on the control panel during machine operation.

- ❖ **KNOW THE WATER SUPPLY FLOW VOLUME:** The standard AquaBlast Elite manifold requires a water supply flow of 4 gallons per minute, 3.9 actual. An extream ultra low flow model is available that requires only 3 gallons per minute, 2.9 actual. Because this is an advanced design, pressurized to create faster washout using less water and higher washout pressures, the volume of water you supply into the unit is very

important. Two different washout manifolds are available, standard flow and extreme low flow. Same machine features but designed for low and ultra low water usage and or supply. Any standard unit can operate low production but it is important to know the low flow unit is built for applications when water supply flow is very limited. Low flow units may have a slightly longer cycle time for film washout but they require less than 3 gallons per minute water supply. Supplying more water flow does not mean the unit will flow more water, always check the supply before making final supply line connections making sure the supply meets or exceeds the machine manifold requirements listed above.

- ❖ After the water inlet hose has been installed, slowly open the customer supplied safety inlet shut off valve and slowly open the machine water inlet valve located at the rear of the unit marked "Water Inlet". Use the manual water washout gun to allow the tank to fill by simply pulling the trigger and holding it open allowing the air inside the tank to bleed from the storage tank permitting tank fill. You must allow all the air out of the holding tank when first filling. This is a **one time event**. Knowing the water supply flow in gallons per minute is a simple and quick test. With the 10 gallon water balance tank and 5 gallon supply flow the fill time is only 2 minutes. Information on how to test the supply flow is listed on the next page.
- ❖ **WASHOUT CHAMBER:** This chamber has been constructed to prevent water escape using the hinged cover, it includes an observation view window. You may leave the cover open if the unit is not be used to help keep the inside dry. The observation window has been supplied to permit cycle observation and a safety switch has been installed to prevent operation with the cover open.
- ❖ **POWER REQUIREMENTS:** The Elite is a single phase unit designed to operate on a dedicated 220 volt Single Phase 60 Cycle power source and the required machine circuit breaker size is 20 amperage. Always consult a qualified electrician for proper machine hook-up and installation and make the electrical connection last after the water inlet and water drain connection have been made. Power is not required to first fill the water tank.
- ❖ **CYCLE DRAIN REQUIREMENTS:** Because this unit only uses the water once the cycle drain capacity must be large enough to handle the standard water flow during machine washout cycle. The unit has a standard discharge drain size of 1-1/2" that can be expanded to 2" or reduced to 3/4" using simple plumbing supplies found at any local hardware store. Water being discharged is located high on the back of the unit for maximum gravity drop into the drain. Always check any drain connection for leaks.....a vertical air draw, **air admittance valve circuit**, has been included with the AquaBlast Elite to allow fast efficient waste water draining.

The Elite is offered with Optional Discharge Sump that includes an automatic pump and water storage receiver needed to store and remove the drained water from the unit when an adequate drain is not located nearby. This allows the sump to conveniently move the used water to any nearby drain, sink or tub. The sump unit also includes an automatic alarm controller that sounds an alarm if for any reason the pump does not operate, this will eliminate any sump overflows that might occur with poorly designed systems. These units are sized and supplied with a pump rated at the required head pressure and volume needed for the application. Placement, size and pump horse power can be affected by head pressure requirements so always consult the factory for information.

- ❖ **PRESSURE TANK DRAIN REQUIREMENTS:** This unit includes an externally operated outside balance tank drain valve that is used to drain the balance tank only, do not confuse this with the washout waste water drain, both are located at the back of the unit...the balance tank includes an inside located standard drain that is factory closed with a remote outside panel mounted closed drain valve. It is not necessary to connect the drain hose during machine set up or operation, only when tank draining is required. This drain can be connected to any standard garden hose and used to empty the water supply inside the unit using simple gravity. The factory has kept the standard balance tank drain closed, it will be necessary to open both the water tank drain and the outside drain for tank draining. Any pressurized system, example home water system, must introduce air into the tank to drain the tank. This is normally done in the home using an

open faucet valve. Always use the manual spray gun to allow air into the water balance tank during tank draining making sure the hose supplying the manual gun has no water inside the hose. Turn off the water inlet into the pressurized water tank, attach the drain hose and pull and open the outside drain valve making sure the tank master drain valve on the tank is open....hold the manual washout gun trigger open to allow air in and water out of the balance tank....make sure the gun is held high to remove the water in the supply hose.

- ❖ **WATER IN CONNECTION:** This unit has a set-up similar to any home operated water heater tank. Water into the unit is under pressure and requires a customer inlet shut off valve on the hot water supply. You are required to connect a pressurized hot water line to the Elite from a customer supplied hot water source. Because the system is pressurized the hose used for machine connection must be quality high pressure type hose rated for hot water supply. Media Blast recommends stainless braided hose for the machine inlet supply with a 3/4" ID but this ID is not required, knowing the supply flow explained later will determine if any special hose ID size is required .... The customer supplied water supply already includes a water inlet shut-off valve that can be used to shut down the supply.. The unit uses standard 3/4" NPT threads to supply water into the main water inlet located at the rear of the unit. Many different types of hoses are available at any local hardware store. The machine Duty Cycle Chart (DCC) is based on a washout times including 30 seconds for load and unload.. After the washout time has been established the Duty Cycle Chart will let you see the production capabilities of the unit listed in washout cycles per hour. The standard model is listed and a load and unload time of 30 seconds has been added to each washout time. The manifold design may affect the total machine duty cycles, only the washout time required affects the total cycles per hour. The exact washout time needed will be established by first running a sample part and knowing the washout time required, this allows you to see the hourly cycle rate of the unit using the Duty Cycle Chart and washout time.

**NOTE:** It is important to know the water supply volume before connection to the Elite. Take time to accurately measure the supply flow volume amount before making the final water supply inlet hose connection, this flow rate must be known and slightly higher than the manifold usage required, 3.9 gpm standard, 2.9 gpm extreme ultra low usage manifold. Water flow is measured in gallons per minute. Using a watch with second hand sweep, flow water into a known water container size for one minute using the location for placement of the new Elite machine and the supply hose used to connect to the new AquaBlast Elite. Make sure the container has adequate capacity to hold at least 5 measured gallons. If the water exceeds 4 gallons in one minute or less you have all the water required for the standard manifold. If the water exceeds 3 gallons per minute in less than one minute you will exceed the flow required for the extreme low flow manifold. Depending on the results and manifold design ordered there is no need to continue with the test. If a 5 gallon container is filled in 45 seconds, stop the test, you will be flowing 6.66 gallons per minute. Divide the gallons flowed by the fill seconds to know flow per second. Multiply this flow per second times 60 seconds to equal the gallons flowed per minute. It is not necessary to run the test for one minute. If the supply hose used is 1/2" ID and it exceeds the required flow rate a 3/4" ID hose is not required.

- ❖ **FILLING THE UNIT WITH WATER THE FIRST TIME:** After testing for water flow the water inlet hose can be attached to the water inlet. Slowly open the customer supplied safety shut off valve and next slowly open the machine water inlet valve located at the rear of the unit marked "Water Inlet". Use the manual touch up gun to allow the tank to fill by simply pulling the trigger and holding open. You must allow air out of the enclosed system to first charge the water holding tank. This is a one time event ...if the supply flow is 5 gallons per minute it will take 2 minutes to fill the tank....continue to fill the tank by holding the manual gun open for one minute after you see manual spray.
- ❖ **REVIEW THE ENTIRE OPERATIONAL GUIDE PRIOR TO MACHINE OPERATION.** Most problems associated with the machine can be identified by simply reading this manual or consulting the Troubleshooting Guide. If your problem cannot be found in the



Troubleshooting Guide, please give us a call. Nearly all equipment malfunction issues can be resolved over the telephone. Almost all problems can be eliminated by reading the manual first!

❖ **CUSTOMER SUPPLIED HOT WATER REQUIREMENTS:** The most common hot water supply uses a standard water heater type tank. The machine duty cycles will determine the water heater tank size needed to supply heated water to the system. Using the machine Duty Cycle Chart helps to properly size the system when knowing the number of cycles you require for daily or hourly operation.

- Example: If the applications requires one hour of 60 second film washouts per day, adding 30 seconds for load and unload means the total water flow into the unit for the standard manifold rated at 4 gallons supply per minute would be 160 gallons per hour. Because the washout temperature is normally lower than history standard, you can use this number to calculate the tank size required to supply the volume per hour to the unit based on tank size recovery. If the unit is expected to supply constant hourly usage an On-Demand type of supply may be required or adding the optional water blending valve will permit both hot and cold water supply reducing the volume of hot water required by 50%. The flow rate in gallons per minute is normally lower than 4 gallons per minute on most on-demand units requiring a blending of cold and hot water if high production is required....ask for details about how to connect and how to further save on heated water. Consult the factory for information about On-Demand requirements and accurate machine Duty Cycle Chart for the temperature setting and volume of the On-Demand supply system. Any On-Demand supply has two important numbers, gallons per minute flow and temperature out. The lower the temperature setting the higher the flow per minute. Many options for machine supply can be calculate including On-Demand blended with cold water to supply a higher supply of gallons per minute using less heated water. This is also possible with any standard hot water supply heater. Anyone using a shower is blending the hot water and cold to achieve a blended temperature using less hot water.

## SET-UP SHEET AquaBlast Elite Washout Machine

The information that follows will be used to get your new AquaBlast Elite machine set-up and operational in the shortest period of time. Use this sheet for the initial machine set-up and operation. You may refer to this sheet at any time, for more detailed operational instructions and machine maintenance refer to the main operational manual or the Important Issues above.

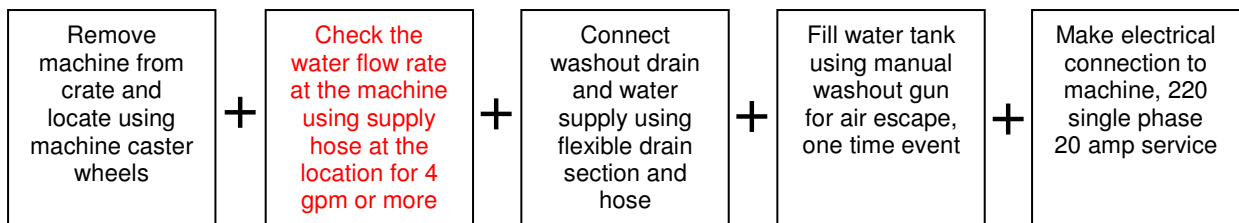

### FIRST

- Remove any lag bolts attaching the machine to the shipping pallet. Remove the machine from the shipping crate being careful to wear gloves and eye protection during the process. The standard machine weight is over 500 pounds, make sure you have adequate lifting abilities before removing from the skid and use the skid to position the unit as close to the final location as possible before removal from the skid. The unit includes castors allowing the Elite to be rolled to the final location.

- Use a forklift taking care to spread the forks to the outside next to the machine casters. Do not lift from the sides marked “No Lifting”. Steady the machine when lifting. Lift the machine just enough to remove the shipping pallet.
- Install the machine allowing adequate clearance for machine front and rear access panel removal. Never allow direct sunlight or harsh overhead lighting to reflect on the machine operator view window located in the top washout chamber.
- Remove any items from inside the cabinet that might have been shipped inside the cabinet, this may include the manual, installation hoses and installation fittings and clamps.
- The water inlet is located on the rear of the unit; see Machine Control Diagram (MCD) for location. Before final connection of the water inlet line check the supply flow in gallons per minute using the information above in the WATER CONNECTION SECTION. MBA has included a master water shut-off valve and 3/4"water inlet shut-off valve on the water inlet line located at the rear of the machine. The water inlet capacity is based on customer flow capacity; see Important Issues above for more information about flow requirements and model selection. The customer supply flow capacity must meet the manifold design. A manual washout gun has been supplied and also used to permit air escape during the first tank fill, see Important Issues above for more information about the first filling. It is advised that you install a master water inlet valve on your hot water inlet supply to allow shut off if you have a hose failure on the supply line. Set the incoming water supply temperature at 90-100 degrees Fahrenheit if the water is not cold water blended, ask for details about cold water blending. Use quality high pressure hot water hose for the water inlet....all internal hose are 3/4" ID stainless steel braided hoses. Because the unit is portable, on casters, never connect using ridged water supply line or ridge final drain connection.
- Make connection to 1-1/2" drain, this may be increased or decreased in size using standard plumbing drain connectors found at any hardware store. You can also use drain hose used to pump motor home gray-water. The unit must include a section of flexible drain hose for final connection to the discharge drain. Never connect using ridged drain discharge line; the discharge of water on commercial property is normally not permitted. Check local codes for restrictions.  
The AquaBlast Elite is available with optional sump including automatic pump and pump alarm for discharge to drains that are not located next to the unit placement...ask for details.

The machine is now almost operational with the exception of the electrical hook-up. This has been left to last to insure the pump is not operated ....Make sure water inlet and cycle drain outlet are connected. Use the manual trigger gun to fill the machine water storage tank by holding the trigger gun open allowing air to exit the tank and water to enter. Water will spray when the tank is half filled and normally fully filled in two minutes. You can check for tank water anytime by using the manual washout gun. The pressurized system does not require a separate pump for the manual washout gun helping to eliminate maintenance but does use and include a pressure amplified manual washout gun. It is not necessary to use the manual washout gun to first wet the drum, you can use the jog control that includes washout rinse for this operation.

- The standard electrical for the Elite washout machine is 220 high-voltage – single phase, 60hz. Check machine nametag for machine electrical service...the unit requires a dedicated 20 amperage circuit.
- Consult a qualified electrician to make electrical connection, refer to Important Issues above for power supply requirements.

**NOTE:**

This unit includes the pump saver design. This design is used to detect “Low Water Supply” in the supply tank. The pump saver design will automatically lower the washout pressure to zero if the water flow into the tank does not match the manifold usage.. This pump saver design will insure the pump and water supply is never exceeded. Always keep the washout cover closed at

all times unless the unit is not being used. Open the unit when not being used to keep the washout chamber dry. Never leave the magnets on the drum when not being used, magnets will pick up small iron particles that rust the drum surface.

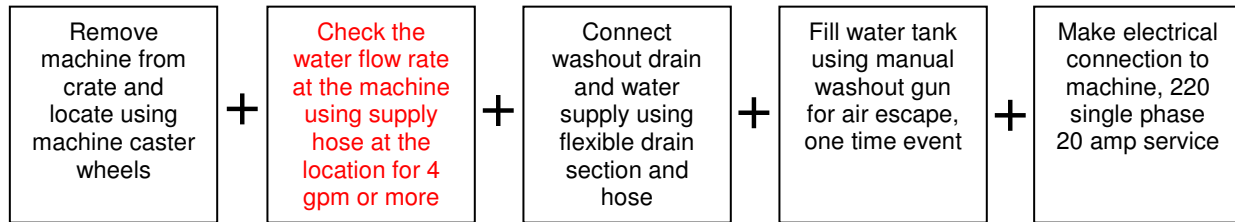

## OPERATION

- Turn the main machine on-off switch to the on position. The switch is located on the control panel; refer to Machine Control Diagram (MCD). Turning this switch to the on position will supply power to the internal pressurized water balance tank and other machine controls.
- Turn the machine on-off LED lighting switch to the on position.
- The adjustable washout cycle timer has been factory set to a 3 minute scale....using the adjustable timer dial, set the time to 60 seconds. Now use a small piece of developed or undeveloped film to test for proper cycle times. This manual includes a general Mask/Film washout time chart for Ikonics Imaging film. This is an estimated time only; time may vary with different inlet water temperatures and or film development times.
- Close the lid and pre-wet the drum using the manual jog with washout cycle button. You can also open and use the manual washout gun to pre-wet the drum....water tension will stick the film in place. After placement of the film on the drum remove two of the strip magnets from the magnetic holding pad and place over the top and bottom edges of the film to protect the edges of the film from the water blast. You can use film edge to edge using one magnet to hold the edges of two films.
- Close the top washout cover making sure to set the lid seal by applying a small amount of down pressure on the lid... press the cycle start button, see Machine Control Diagram (MCD) for location. The unit will start drum rotation, activate the high pressure pump and continue film washout for the time setting on the cycle timer. You can view the process using the observation window located in the top cover. LED lighting has been added to allow jet spray observation as well and general film washout condition. In addition, the pump pressure and water temperature are also monitored on the control panel, left side. Because this unit is an enclosed pressurized unit with maximum insulation the water temperatures required may be less than other units. The enclosed pressurized system also is capable of much higher processing pressure. Water pressure is the single most important factor when doing any film washout. The Elite has the highest processing washout pressure in the market today, do not be fooled by units that do not offer direct pressure and temperature readouts. After the cycle timer has timed out you can use the manual jog button with rinse to continue the washout for short time periods if needed... you may then open the cover and remove the magnets and film making sure to lift the magnet edge from the film to the film edge. Store the part holding magnets on the magnetic pad located on the front of the cabinet. Remove the processed film and store for drying; next re-load with new film for the next washout.
- Duty cycle has been determined by washout time plus 30 seconds load and unload time. The Duty Cycle Chart (DCC) has been calculated using the washout time period and load and unload time. Low flow and High Flow will have different washout times, the Duty Cycle Chart (DCC) will show the maximum cycles per hour solely based on cycle washout time required. See the Duty Cycle Chart (DCC) for more information.

Longer washout times will reduce total hourly cycles on any unit. Low flow manifold may reduce the hourly cycle rates.

- Know the water supply volume meets the minimum flow before you start to process.
- Make sure to place the film between the center lines of the right and left fan jet, never use outside the center line of the last jet on each side of the zone for film washout.. Jets overlap and the last jet on each side, past center line of the jet, will process film washout at a slower rate than jets with overlapping jets on both sides. Additional manifold jet outlets have been supplied for future manifold expansion if required. This will permit the washout of wider stock but slightly reduce pressure that may slightly increase washout times and demand for water flow into the unit. The drum has also been oversized to allow for future film width expansion. Additional jets will affect machine water usage; ask for details before changing the manifold jet number or size.
- Never point the manual washout gun at people or pets!
- The unit also includes a manual jog with rinse to permit extra washout seconds to be added to the cycle.
- The observation window and LED lighting can be used to insure proper jet operation and fan placement....always interesting to see the process and the new Elite allows you this important feature.
- If the machine is not going to be used, turn the main power button to the off position and open the washout chamber cover.

Below is a general Duty Cycle Sheet for the AquaBlast Elite washout machine...The maximum cycles per hour is based on the film washout time and the estimated load and unloads time of 30 seconds. Using the sum of these two figures allows the hourly cycles of the equipment to be listed. You can use this chart for both extreme low flow and the standard manifold models, if the washout time is 60 seconds you can load, washout, unload and load 40 cycles per hour and not worry about ever running out of water.

## Machine Cycles Per Hour

Maximum cycles per hour based on 30 second film unload and load time	<b>DUTY CYCLE CHART</b> cycles per hour based on washout cycle times listed						
		51	45	40	36	32	30
	Washout Time	40 sec.	50 sec.	60 sec.	70 sec.	80 sec.	90 sec.
	All cycles per hour based on film washout time plus 30 second load and unload time						
Maximum cycles per hour based on 30 second film unload and load time	<b>DUTY CYCLE CHART</b> cycles per hour based on washout cycle times listed						
		27	25	24	23	20	17
	Washout Time	100 sec.	110 sec.	120 sec.	130sec.	150 sec.	180sec.
	All cycles per hour based on film washout time plus 30 second load and unload time						

# SERVICE & MAINTENANCE

<b>MINIMUM RECOMMENDED MAINTENANCE SCHEDULE FOR YOUR MACHINE</b>						
<small>(replacement schedule can vary depending on equipment usage and other factors)</small>						
<b>MAINTENANCE PROCEDURE</b>	<b>EVERY 4 HRS</b>	<b>DAILY</b>	<b>WEEKLY</b>	<b>MONTHLY</b>	<b>SEMI- ANNUAL</b>	<b>ANNUALLY</b>
Inspect Water Jet for proper spray pattern		X				
Inspect Hoses for leaks		X				
Inspect Drain Outlet for leaks		X				
Inspect pump cycle pressure		X				
Remove and clean Y-Strainer screen				X		
Visually inspect drain pan	X					
View pressure & temperature gauge		X				
Replace manifold jets					X	X
Inspect and replace washout lid seal						X
Visual inspection with side panel removed				X		

**TABLE 3: MINIMUM RECOMMENDED MAINTENANCE SCHEDULE**

**INSPECTING THE FAN JETS:** Fan jets should be inspected on a daily basis using the operator view window and LED lighting during any machine cycle.... Using the LED lights makes visual inspection easy. Look for any “V” spray patterns that affect washout consistency or any variation in fan jet pattern . When a bad pattern is noticed count the jet number from left to right or right to left and remember. Open the access cover and remove and cleanout any nozzles that indicated a bad spray pattern. All nozzles include an internal screen matched to the nozzle size. Many different optional nozzle patterns and materials are available on the new Elite, Always use a blow-off gun to clean and clear any nozzle found to be defective. Do not drill....dig....scratch or mutilate any jet during cleaning.

**WARNING:** The Elite has a high pressure pump assembly. Pressure is the most important washout factor related to performance. Operation using a worn out set of fan jets may flow more water and reduce the pump pressure to zero if inlet flow is marginal.

It is advised that fan jets be replaced in sets and not random replacement. This maintains the fan jet washout consistency and washout pressure consistency needed to maintain maximum daily film washout production. If no reduction in the washout pressure is recorded on the manifold pressure gauge the jets are normally OK ....continued usage may increase machine demand for water. Remember this unit is a low flow design and the jets determine the water usage. Worn out jets require more heated water supply and the cost of jet replacing will be saved in heated water usage.

**REMOVE, INSPECT AND CLEAN THE Y-STRAINER:** The water inlet located on the back panel includes a Y-Strainer used to protect the unit from small debris found in new and old water lines. The screen size supplied is used to protect the fan jets and any solenoids used for machine operation. This screen requires monthly removal and inspection. If the screen appears clean the monthly inspection may not be required.

Close the water inlet valve located on the rear panel and remove the side panel exposing the Y-Strainer located on the inside sidewall of the lower cabinet.. Use the manual washout gun to remove any pressure existing in the enclosed water tank. It is advised that the tank be drained when removing the Y-Strainer Screen. Use appropriate tools to remove the Y-Strainer screen, inspect and clean. Replace the screen, tighten the access nut and again open the water inlet valve making sure the strainer has no visible leaks. If the tank was drained it will be necessary to bleed the tank of air to permit tank filling, see filling with water in the set-up sheet for procedure.

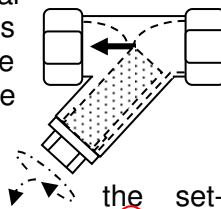

**WASHOUT COVER SEAL:** The washout cover includes a removable bladder seal used to keep the system neat and clean. The pressurized enclosed system is the cleanest design you can purchase today.

This bladder seal may wear out or become damaged during high machine duty cycle. Replacement is quick and simple and if the seal gets damaged or torn, simply replace to keep the machine operation looking neat and clean. Pull-off to remove and push-on new to replace. To turn a 90-degree corner use a simple set of nips to notch a 90-degree "V" pattern on the inside of the holding clip so it is located on the corner. This will permit a 90-degree turning of the bubble seal assembly.



**CHANGING THE JET MANIFOLD HEIGHT:** The Elite includes an adjustable fan jet washout distance that can be easily changed. The manifold can be tested at different heights depending on the fan jet spread and fan jet pattern being used. To change the distances remove the threaded handles holding the manifold in position. After removal of the two threaded handles it will be possible to move the manifold to the back of the unit. Make sure you locate and use matching horizontal holes and re-install the threaded holding handles after selecting the new location. It is important to have the jets overlapping without conflicting patterns. Always make sure the jets are slightly angled in the anodized manifold, the pattern is visible through the observation window when the unit is running. The fan angle can be used for additional settings of the manifold distance. The fan pattern of each jet should reach center-line of the jet next to it. Test, observe and change using the observation window and LED lighting.

**SETTING THE CYCLE TIME:** The washout cycle timer has many different time settings, the factory setting is 0-3 minute maximum cycle time. Use the movable dial to set for appreciate cycle time. When the dial is set the timer will not need to be set again unless the film thickness or type is changed. When the timer cycle ends it automatically re-sets for another repeat cycle time.

To change the dial time setting, any washout 3 minutes and under will not require changing, look for the small mode adjustment switch located in the upper right hand corner of the timer. Using a small flat blade screw-driver you can change the mode setting of .05 seconds to 300 hours. Make sure the adjustment switch is clicked into any new location.

Using the dial with graphic display of 0, .5, 1 to 3 indicating minutes, set the dial for the washout time required for the film being used. Simply rotate the dial clockwise or counter-clockwise to change the time. This is a simple 8-pin timer that is easily replaced if replacement ever becomes necessary.

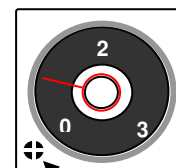

**READING THE PRESSURE AND TEMPERATURE:** The temperature and pressure gauges are located on the operator panel of the new Elite. Starting the washout cycle will allow the operator to see the pump performance and water temperature during the washout cycle. Please remember this unit includes a high-pressure pump assembly that reduces the washout

cycle time and or water usage. Always use a piece of undeveloped or developed film to check for proper cycle time setting....record and develop a simple chart for times vs. type and thickness for the films being used.

**WINDOW REPLACEMENT:** The new Elite includes an observation view window in the washout chamber. The window uses a positive locking window molding to eliminate leaks and permits washout viewing. Use this window to check for proper placement of the fan-jet distance, proper fan jet angle and also check for proper fan-jet function. The following steps outline window replacement:

1. Locate locking strip end and remove strip from window molding.
2. Holding one hand firmly against the outside of the window, push the window from inside to outside and remove the window from the molding.
3. Apply silicone spray or equivalent to the locking strip slot and the window slot. Soap will work if sprays are not available.
4. Place lower left-hand corner of the window into the window slot at mid-window (FIGURE 4a).
5. While the window is being pushed toward the left side of the cabinet, bring the window to level position and guide the top left window corner into the top molding window slot (FIGURE 4b).
6. Push the window into the left side of the window molding slot. Use the plastic stick from the Window Molding Tool Kit (part no. 100-18-123) if necessary.
7. With the aid of the plastic stick, install the second half of the window into the molding slot by inserting the stick between the outside of the window and the window slot. Move the stick around the perimeter to the lower half of the window (FIGURE 4c).
8. With the aid of the window locking strip tool (Window Molding Tool Kit), install the locking strip (FIGURE 4d).
9. Locate locking strip end and remove strip from window molding.
10. Holding one hand firmly against the outside of the window, push the window from inside to outside and remove the window from the molding.
11. Apply silicone spray or equivalent to the locking strip slot and the window slot. Soap will work if sprays are not available.
12. Place lower left-hand corner of the window into the window slot at mid-window (FIGURE 4a).
13. While the window is being pushed toward the left side of the cabinet, bring the window to level position and guide the top left window corner into the top molding window slot (FIGURE 4b).
14. Push the window into the left side of the window molding slot. Use the plastic stick from the Window Molding Tool Kit (part no. 100-18-123) if necessary.
15. With the aid of the plastic stick, install the second half of the window into the molding slot by inserting the stick between the outside of the window and the window slot. Move the stick around the perimeter to the lower half of the window (FIGURE 4c).
16. With the aid of the window locking strip tool (Window Molding Tool Kit), install the locking strip (FIGURE 4d).

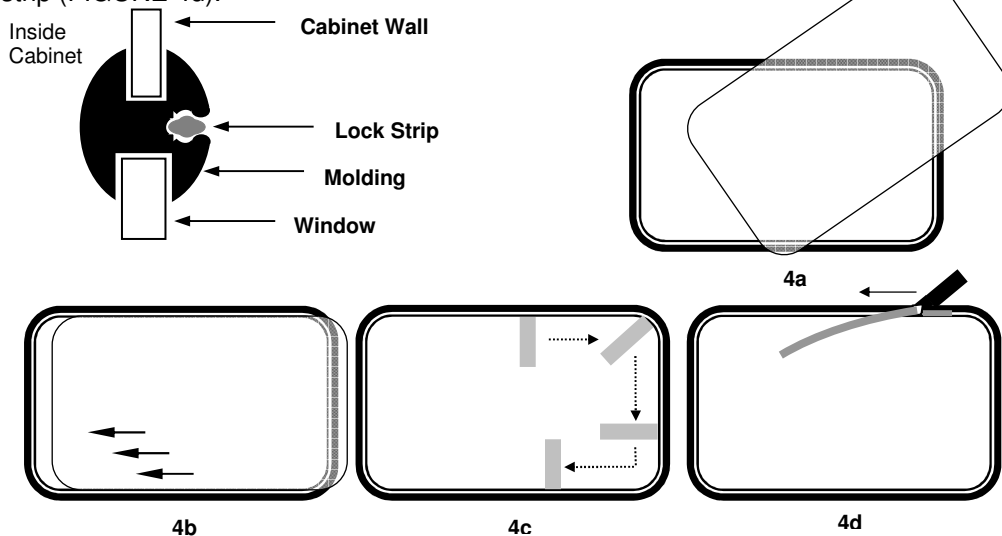

SAFETY VIEW WINDOW REPLACEMENT

**FLANGE BEARING:** The unit includes permanently lubricated bearing requiring no service.

**OPTIONAL SETTLING TANK with AUTOMATIC PUMP & ALARM:** Many types and sizes for optional settling tanks can be used with the new Elite washout machines. The material construction, automatic pump head pressure and alarm controls are commonly used when a drain is not located in close proximity of the washout unit.

Call and discuss this available option with Ikonics Imaging or Media Blast Sales department.

**PUMP SOLENOID VALVE:** The Elite is a pressurized system for higher performance using less water and includes a master solenoid water valve. This valve requires no maintenance. If the cycle stops and the fan jets continue to emit low pressure water flow the solenoid may have a piece of debris under the diaphragm and require cleaning. Make sure the washout cover is closed and with the front panel removed locate the valve, valve location is on the pump inlet. It will be necessary to disassemble the valve to clean the solenoid.... An optional high flow panel mounted sediment filter can be added to the unit that includes a manual purge valve for quick cleaning...ask for details.

**MANUAL WASHOUT GUN:** The manual washout gun is also used to fill the pressure tank for the first time allowing air out of the tank during first filling. This gun requires no service, replace when faulty or leaking.

**JOG WITH WASHOUT:** The jog with washout requires no service. It is used to pre-wet the drum and can also be used to add a small amount of washout time manually to any cycle.

**MAGNET STORAGE PAD:** The magnetic storage pad requires no service or maintenance, used to store the magnets when not in use.

**FRONT AND REAR PANEL REMOVAL:** The removable panels are used to service and or replace any defective parts. Removal is simple and quick....remove the two panel holding screws at panel bottom and use the lift hole to lift, pull and remove the covers. Always make sure the electrical is locked out before doing any machine service.

**DRAIN PAN:** The new Elite has a welded two piece drain pan assembly, it is important to daily inspect and clean the pan assembly to maintain proper drain flow. Small film debris can impede water flow out of the unit.

**DRAINING THE WATER BALANCE TANK:** To drain the pressure tank first make sure the Power On switch is off...attach a simple garden hose to the drain outlet of the cabinet, see Machine Control Diagram (MDC) for location. Turn the water supply source inlet valve to the off position. This is the valve located on the inlet of the customer supplied hot water supply and the back of the machine at the water inlet. Make sure the drain location is acceptable and open the machine drain valve for the pressurized water tank. Hold the manual washout gun open to allow air into the tank and water out of the tank. Make sure the water tank valve is open during draining process and hold the manual gun high to allow water out of the hose and air in.



# TROUBLESHOOTING YOUR ELITE WASHOUT UNIT

## PROBLEM

## SOLUTION

### Pump cycle pressure reads zero

- ❖ Water supply volume, gpm, is less than manifold demand, check supply flow making sure 4 gallons per minute is supplied..
- ❖ Check the flow volume (gpm) using the test on page 6 and 7 of this manual
- ❖ Too small water supply hose, measure supply flow for gpm..
- ❖ Water inlet valve is closed, check both customer supplied and machine inlet..
- ❖ Balance tank has not been filled, see page 6 and 7 of this manual
- ❖ Worn out fan jets, higher flow than supply will result in zero pressure, replace jets
- ❖ Plugged Y-Strainer, shut down and clean strainer screen..install sediment filter if the Y-screen requires cleaning more than yearly

### Inconsistent film washout

- ❖ Bad film development, consult Ikonics for reasons why
- ❖ Bad fan jet pattern, using the LED lighting observe fan jet pattern for bad fan jet pattern..remove and clean fan jet..
- ❖ Bad fan jet angle, use the view window to check for proper fan jet angle using LED lighting..
- ❖ Placement of film beyond the right and left fan jet centerline...reposition film location during washout..
- ❖ Incorrect fan jet distance, using the washout cycle and LED lighting with on film in place, make sure the fan jets overlap centerline of fan jet on either side. Use the adjustable height to change overlap setting..use the fan jet angle for fine settings...
- ❖ Check fan jet manifold angles making sure the visual appearance during operation looks the same...adjust as required.
- ❖ Short cycling the washout, add time to the washout timer..
- ❖ Water temperature variation, check temperature using washout temperature gauge..

# PARTS LIST

HARDWARE	QT	PART NUMBER
Safety window	1 each	115-08-125
Window molding with lock strip	1 each	115-08-126
Washout lid seal	1 each	101-11-147
Washout lid handle	1 each	115-08-111
18" magnet strips	6 each	100-11-604
Locking caster wheels	4 each	115-09-112
Flange bearing, drum drive	1 each	115-09-103
Drum 16"x 18"	1 each	115-08-112
Drive coupling	1 each	115-09-106
Top plastic edge trim	1 each	115-08-114
Stainless enclosure pivot pins	2 each	115-09-108

## WASHOUT

Manifold	1 each	115-08-100
Manifold plugs, 1/4"	6 each	115-09-109
Washout fan jets	6 each	115-08-120
Water supply hose, cabinet to balance tank inlet, 30"	1 each	115-08-106
Water supply hose, balance tank outlet to pump inlet,30"	1 each	115-08-106
Water supply hose, balance tank outlet to pump inlet,18"	1 each	115-08-107
Water supply hose, pump outlet to cabinet, 24"	1 each	115-08-108
Water supply hose, cabinet to manifold inlet, 30"	1 each	115-08-106
Booster pump, 1-1/2 hp	1 each	115-08-102
Solenoid valve pump inlet	1 each	115-09-102
Manual washout gun	1 each	115-09-111
Manual washout gun hose	1 each	109-15-601
Balance tank, 10 gallon	1 each	115-08-103
Balance tank hose, tank drain to cabinet	1 each	115-08-109
Water inlet valve, 3/4"	1 each	104-26-122
Water balance tank drain valve, 3/4"	1 each	104-26-122
Water temperature gauge	1 each	115-08-104
Water pressure gauge	1 each	115-08-110

## ELECTRICAL

Gear-motor drive	1 each	115-08-100
Gear-motor conduit box	1 each	115-08-101
LED lighting	1 each	115-08-115
Emergency stop switch	1 each	115-08-116
Cycle switch	1 each	115-08-117
Jog switch	1 each	115-08-118
Power on switch	1 each	115-08-119
Timer	1 each	115-08-113
LED lighting switch	1 each	115-08-121
Limit switch washout enclosure	1 each	100-22-090
750 watt maintenance heater element	1 each	115-08-122
CONSULT FACTORY FOR ELECTRICAL PANEL PARTS		

## WARRANTY

Media Blast & Abrasives, Inc., hereinafter known as “ Seller” , warrants the equipment and products sold hereunder against defects in material and workmanship for a period of one year from the date of shipment to buyer.

Equipment, products or parts manufactured by others but furnished by seller will be repaired or replaced only to the extent of the original manufacturer’ s warranty (except motors).

The following conditions apply to limitations:

1. High wear parts are not covered, these parts include window, fan jets and lid seal.
2. Warranty does not apply to misuse of the machine to include improper abrasive type use and or abrasive mesh size used in the equipment. Water conditions may require the installation of a viable water filter.
3. The machine warranty is not transferable and only applies to the original buyer.
4. Replacement warranty parts will be sent at no charge to the buyer for warranty replacement. The cost of labor is not covered under the machine warranty unless preformed at the sellers facility.
5. A Returned Goods Authorization (RGA) form must be obtained before the product is returned to seller for warranty repair. Without an RGA number the product will not be accepted.
6. Seller’s entire liability, whether under warranty, contract, negligence, or otherwise, shall be limited to repair or replacement, F.O.B. Seller’s place of business, of the original equipment found to be defective within the warranty period.



**MBA** Media Blast & Abrasive Inc.

# MACHINE CONTROL DIAGRAM

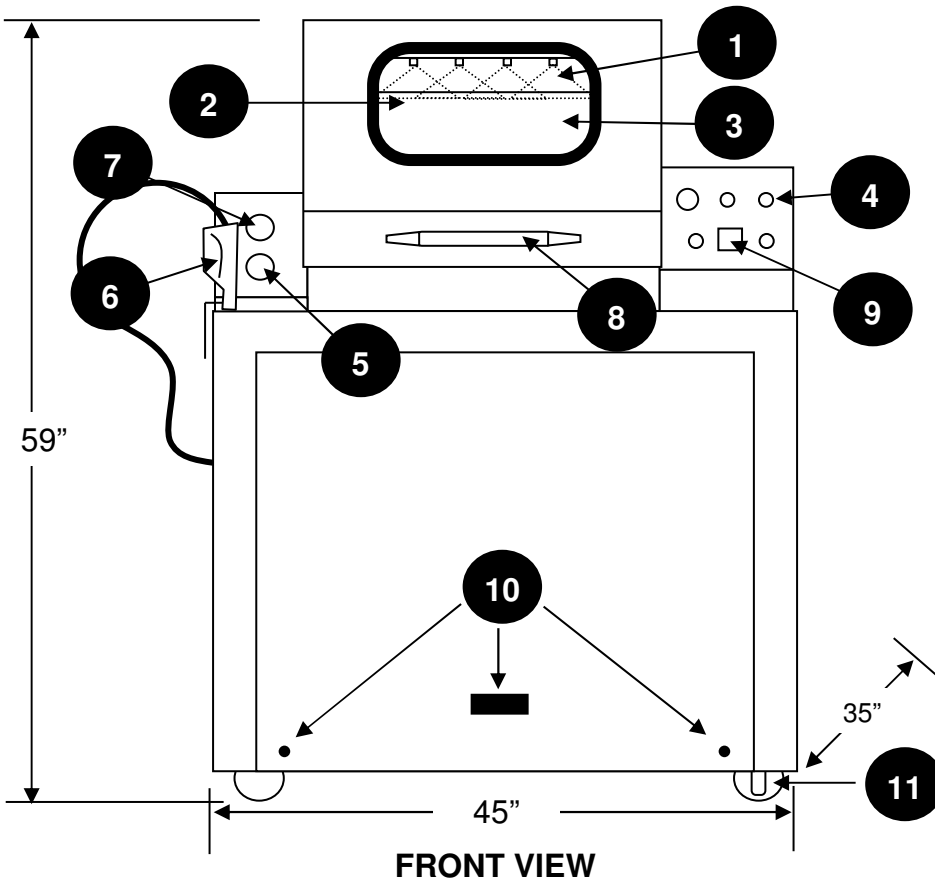

## KEY

1. Washout manifold, fan jets and LED lighting
2. Washout drum
3. Observation view window
4. Controls (top to bottom, left to right), Red Emergency Stop – Green Cycle – Jog with Pressure Rinse – 2<sup>nd</sup> row, Power On – Cycle Timer – LED Lights
5. Water temperature gauge
6. Manual washout gun
7. Water pressure gauge
8. Lifting handle
9. Cycle timer
10. Panel lifting hole and removal screws
11. Locking casters

## KEY

12. Water in
13. Waste water drain
14. Water balance tank drain
15. Panel lifting holes and removal screws
16. Electrical cord strain relief connector
17. Safety switch

220 volt – Single Phase,  
60 Hz – 20 Amp.  
Service

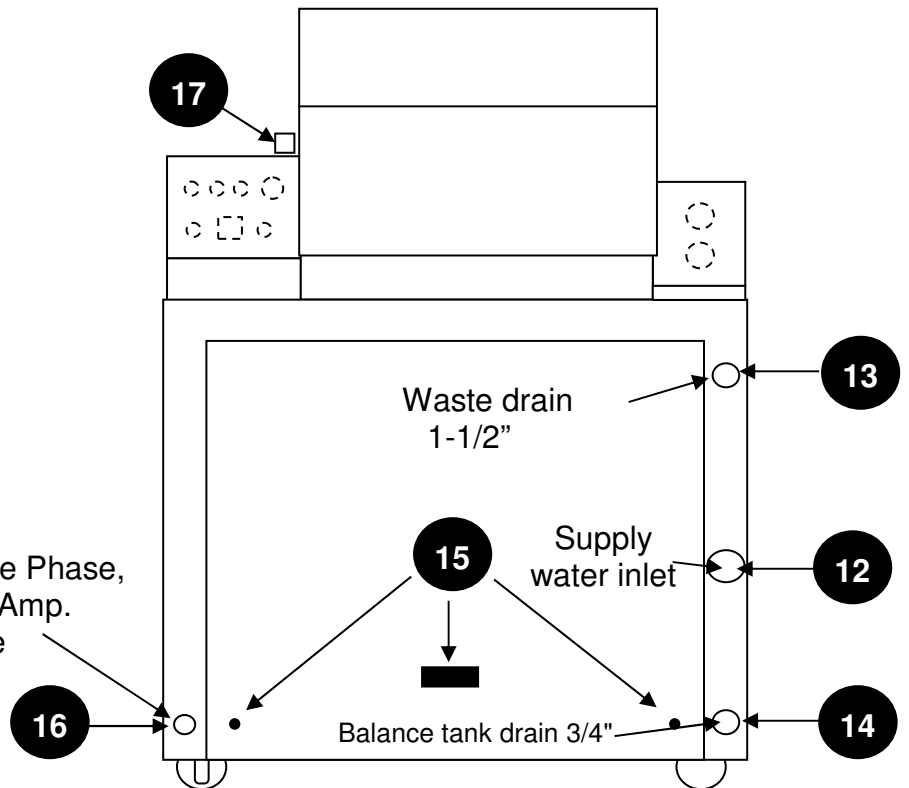

## REAR VIEW